

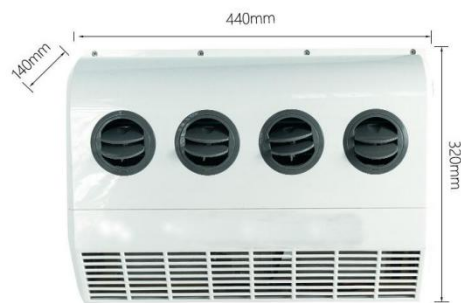

DC Air Conditioner User Manual

Model Number: MT-HS23P (Pro)



1. Packing List

1.1 Cooler (Indoor Evaporator) Part's List

Cooler Part's List (Indoor Evaporator)			
No.	Item	Quantity	Note
1	Cooler	1	Expansion Valve Included
2	Remote Control	1	Standard
3	Battery	2	Standard
4	Drain Pipe	1	Standard
5	Insulated Cotton	2	Standard
6	Three-way valve	1	Standard
7	Nut & Screw	4	Standard
8	Positive and negative power lines	1	Standard

1.2 Condenser (Outdoor) Part's List

Condenser Part's List (Outdoor)			
No.	Item	Quantity	Note
1	Condenser	1	Standard
2	High & low pressure connection tube	1	(Optional)
3	Power cord	1	(3 meters)
4	Manual	1	Standard
5	Bracket	2	Standard
6	Support Frame	2	Standard
7	Nut & Screw	10	Standard

2. Product Technical Parameters

2.1 Specifications

DC Air Conditioner Model	MT-HS23P
Power Supply	DC24V
Working Voltage Range (V)	19V - 32V
Nominal Capacity (W)	1500W~2300W
Input Power (W)	520W~860W
Current (A)	21A~36A
Weigh	Cooler=6.5kgs
	Condenser=23kgs
Connecting Pipe	Low Pressure Pipe, M22×1.5
	High Pressure Pipe, M16×1.5
External Dimension	Cooler, 480×146×320mm
	Condenser, 420×220×380mm

2.2 Test Condition

Test Condition	
Power Supply	DC24V
Condensing Temp	45℃
Evaporating Temp	3℃
Suction Temp	15℃
Subcooling Temp	38℃
Ambient Temp	35℃

2.3 Range of Application

Ambient Temp Range	15~43°C
Evaporating Temp Range	-15~15°C
Condensing Temp Range	35~60°C
Refrigerant Filling. (Max)	1200g
Cooling Temp Range	-0~30°C

3. Installation Instruction

3.1 Installation Notice

The products have nitrogen leakage test before they go out.

Pumping vacuum and adding 750g R134A refrigerant is needed before connecting all pipeline.

The aircon unit can be only powered by 12V vehicle lead-acid battery which meets national standard requirements (GB/T5008.1-2013、GB/T5008.2-2013、GB/T5008.3-2013) .

Then in series to 24V/48V/60V/72V battery unit.

(Note: The voltage must be in the range of 21.5V-27V. High or low voltage will damage the aircon unit)

3.2 Installation Instruction

3.2.1 Inspection before Installation

The aircon condenser needs to be moved and installed by two person.

Unpack the unit and check if there is any damages or anything abnormal.

Prepare installation tools, then check if standard accessories are complete. Accessories packing list is in the attachment.

3.2.2 Wiring Connection Requirement

Confirm the position of battery, then connect the power wire and fixed position properly

Fix the power cord with ribbon to prevent vibration and wear.

Red wire is positive +

Black wire is negative -

PCB will be burned out if connecting the wire contrarily.

3.2.3 Installation Position Selection

Choose the place where is flat and able to support the weight of the unit. You can add some mounting brackets if necessary.

Please try to install the cooler closes to car roof, make for air circulation.

Plus, install the cooler and condenser closely to make the pipeline as short as possible.

The cooler is better to be installed in the position where is good for air in&out.

Installation Recommendation:

Top of Co - pilot/Back top of cab

Condenser should be installed in the position where will not influence the air in and heat air out.

Position Recommendation

Back of Cab- needs to confirm if the cab can support the weight of the condenser.

Frame behind driver's cab- longer connecting pipeline needs to be reserved for cab up and down.

The air inlet size of cooler and condenser should be more than 10cm

The air outlet of condenser must be at least 30cm.

3.2.4 Cooler Installation

Confirm the installation position according to the wiring connection requirements

Fix the wall board according to the cooler installation position and pipe connection.

Please make sure there is at least 4 fixed points between wall board and cab.

The places where the holes are punched must be consulted with the car manufacturer in advance, to make sure it will not influence the car's circuit, structure and function.

Also the cooler must be mounted horizontally.

3.2.5 The condenser Installation

Confirm the installation position according to the wiring connection requirements

If install the condenser on the back of cab, please make sure there is at least 10 fixed points.

MT-HS23P Installation Diagram

Unit: mm

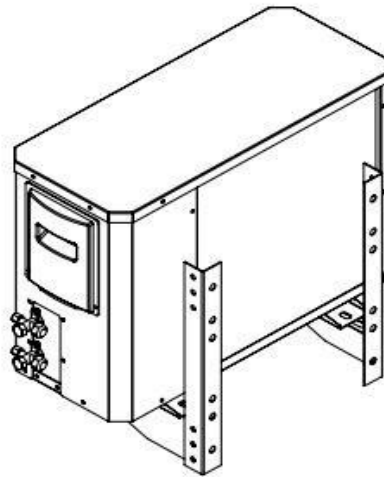
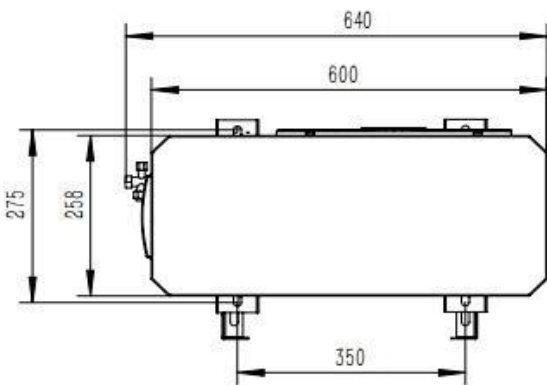
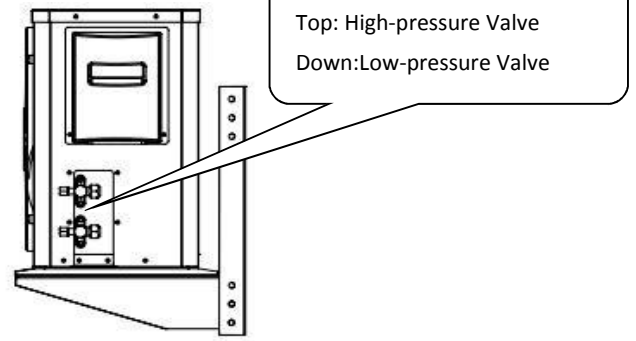
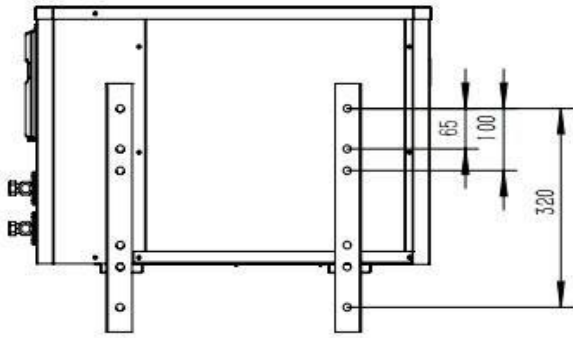

3.2.6 Wire Connection between Cooler and Condenser.

Connect Cooler and Condenser with the two signal wire which is attached with the unit

Positive pole(+) connects the red wire of condenser, and Negative pole (-) connects black wire.

Cooling system high&low pressure pipeline connects condenser tightly fixed by the nut of aluminium joint and cooler by expansion valve

Cooler drain pipe and high&low pressure pipeline is connected by ribbon

Please Don' squeeze the drain pipe, otherwise it will influence drain away the water.

Cover the tube hole with rubber to prevent to damage the high&low pressure pipe.

3.2.7 Add refrigerant in vacuum

Firstly, check the high and low pressure pipe are connected well.

You can add 1.2~1.4MPa R134a refrigerant or nitrogen for leak test if necessary.

Connect pressure gauge with vacuum pump and high&low pressure charging valve

Open the high&low pressure charging valve in pressure gauge.

Then start the vacuum pump to pump vacuum at least 15minutes until it arrives to -0.1MPa

Close the valve, and stop the operation of vacuum pump.

Please keep it more than 5 minutes, to make sure whether the needles in the pressure gauge will come back or not.

If the needles come back, then check the leak position, and start to vacuum pump again.







If not, start to charge, vent air from the vent hose at first, then open the high&low pressure charging valve in pressure gauge, and add R134A refrigerant in 700g, cannot exceed 800g.

If the length of high&low pressure connecting tube is more than 5meters, then add refrigerant 30g per meter.

4. Operating Instruction

4.1 Cooler Controller Instruction



1. Press the on/off button  to start cooler.
2. Press Cool Button to start condenser , and enter into refrigeration mode.
3. Press and hold the button , enter into the mode of adjusting under-voltage protection value.
4. Press the button  to select the working mode.
5. Press and hold + button  to decrease air flow
6. Press and hold - button  to increase air flow

4.2 Voltage Check& Battery Protection

Press the power button to start the unit,

Then you can see the battery voltage on the lower left of LCD.

It will be changed according to battery power.

As there is various type battery, please note that factory setting protection value is 21.5V.

If you want to adjust the value, press & hold COOL button, then enter into voltage regulation mode.

5. Wire Connection

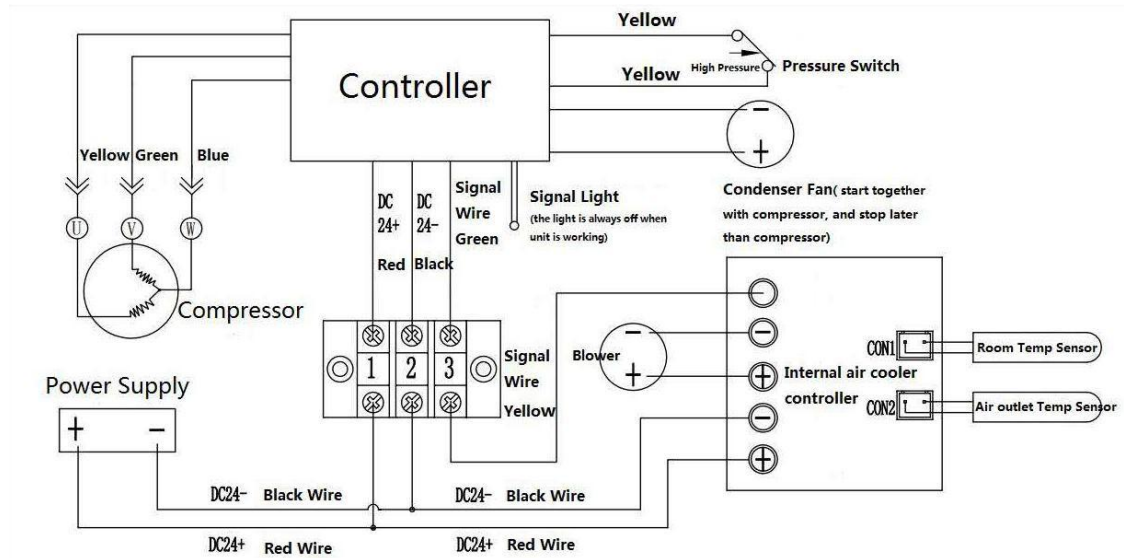

6. Troubleshooting

Fault diagnosis	Troubleshooting
A/C fail to work	<ol style="list-style-type: none"> 1. Check Switch if well-connected? 2. Battery power capacity? 3. Earth leakage protection?
Compressor fail to start	<ol style="list-style-type: none"> 1. Battery power capacity? 2. Compressor protection?
Poor Refrigeration	<ol style="list-style-type: none"> 1. filter screen blocking? 2. Air Inlet & outlet pipe blocking? 3. Sun shining directly into the car? 4. Is the wind horizontal or upward?
About temperature display	Because of the temperature difference in the car, as well as different air speed, there will be the difference data between the display and detected by users

7. Fault Signal Light Instruction

Light flashed Once: Under voltage or over voltage

Twice: High&low voltage protection

Third: Fail to start or cannot control compressor

Fifth: Controller temperature is too high

Sixth: The unit current is too high, exceed protection value.

Seventh: Compressor is overloading or broken

High pressure side ↑ Low pressure side ↓ (Compressor works normally)	lack of refrigerant (There's bubble and expansion valve get frozen through the sight glass)	Find the leaking, refill refrigerant.
	Insufficient heat exchange	Clean heat exchanger
	Expansion valve plugging	Change
High&Low pressure side ↓	Lack of refrigerant	Find the leaking, refill refrigerant
	The expansion valve opens too small	Change
High&Low pressure side ↑	Too much refrigerant	Release certain of refrigerant from the low pressure side
	There's air inside the system	Checking
	Insufficient Condenser	The radiator is deformed and blocked
	Piping blockage at high pressure side	Any bend in the pipe line
	The expansion valve opens too large	Checking

8. Common faults and treatment methods

It needs to be tested and disassembled by specialists only.

Following are the common faults and treatment methods:

(Condition: Ambient Temp 35°C, high pressure range 1.1~1.3MPa, low pressure range 0.2~0.35MPa)

Fault phenomenon	Fault diagnosis	Troubleshooting
High pressure side ↑ Low pressure side ↓ (Compressor doesn't works)	High-voltage tube plugging	Change (large temperature difference)
	Accumulator & Drier plugging	Change
High pressure side normal, Low pressure side ↑	Expansion valve opens too large	Change
	The inlet air temp of evaporator is high	Lower the inlet temperature
The pressure @ low-pressure side up and down	Water in the system	Re-vacuum and refill refrigerant
The pressure@ low-pressure ↓ The pressure@ high-pressure ↓	Low pressure pipeline plugging	Clean or change pipe

Voltage is too low or too high	Voltage checking	steady voltage
The terminal wire loose	Terminal checking	Fastness
Compressor stops working for protection: 1. over-current protection 2. over-heat protection 3. Voltage protection 4. Overloaded protection 5. Locked-rotor protection	1. System overloaded 2. System overheated 3. Voltage too low or too high 4. Compressor rotor-locked	Keep ventilation & Steady Voltage
System pressure protection	Check if condenser is blocked? the fan works? Refrigerant leaking?	Clean Condenser or change fan motor, find the leaking, refill refrigerant.
Compressor on and off frequently	Check if temperature probe is normal	Change
Compressor Speed abnormal	Check Controller	Change
Compressor fail to start	Check controller & compressor	Change